

NO	PART#	REV	NAME	QTY.
1	004-090-00		WASHER, FLAT, NYLON, .75 OD X .406 ID X .032	2
2	004-091-00		WASHER, FLAT, NYLON, .75 OD X .390 ID X .062	2
3	42-0617-00	1	40 SERIES AXLE PIN SUB ASSEMBLY	2
4	41-0072-00	2	HOUSING, FLEX SECTION, BLACK	1
5	11-0650-00	1	BRAKE HANDLE ASSEMBLY	1
6	004-019-00		WASHER, BELLEVILLE	2
7	41-0191-00	Q	SCREW, SPECIAL HEX, 1/4-28	2

REVISIONS			
REV.	DESCRIPTION	DATE	APPROVED
1	new washer stack at axle pins, 5.5" spring was 5"	10.30.13	STRO
2	castle nut was gear nut	06.04.20	CHASE

2X BLUE LOCTITE, TIGHTEN DOWN,
BELLEVILLE WASHER TO BE FLAT

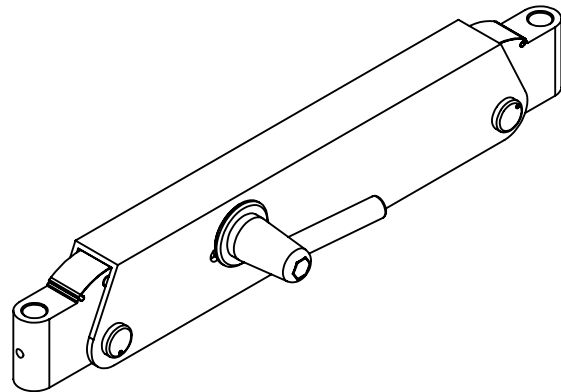
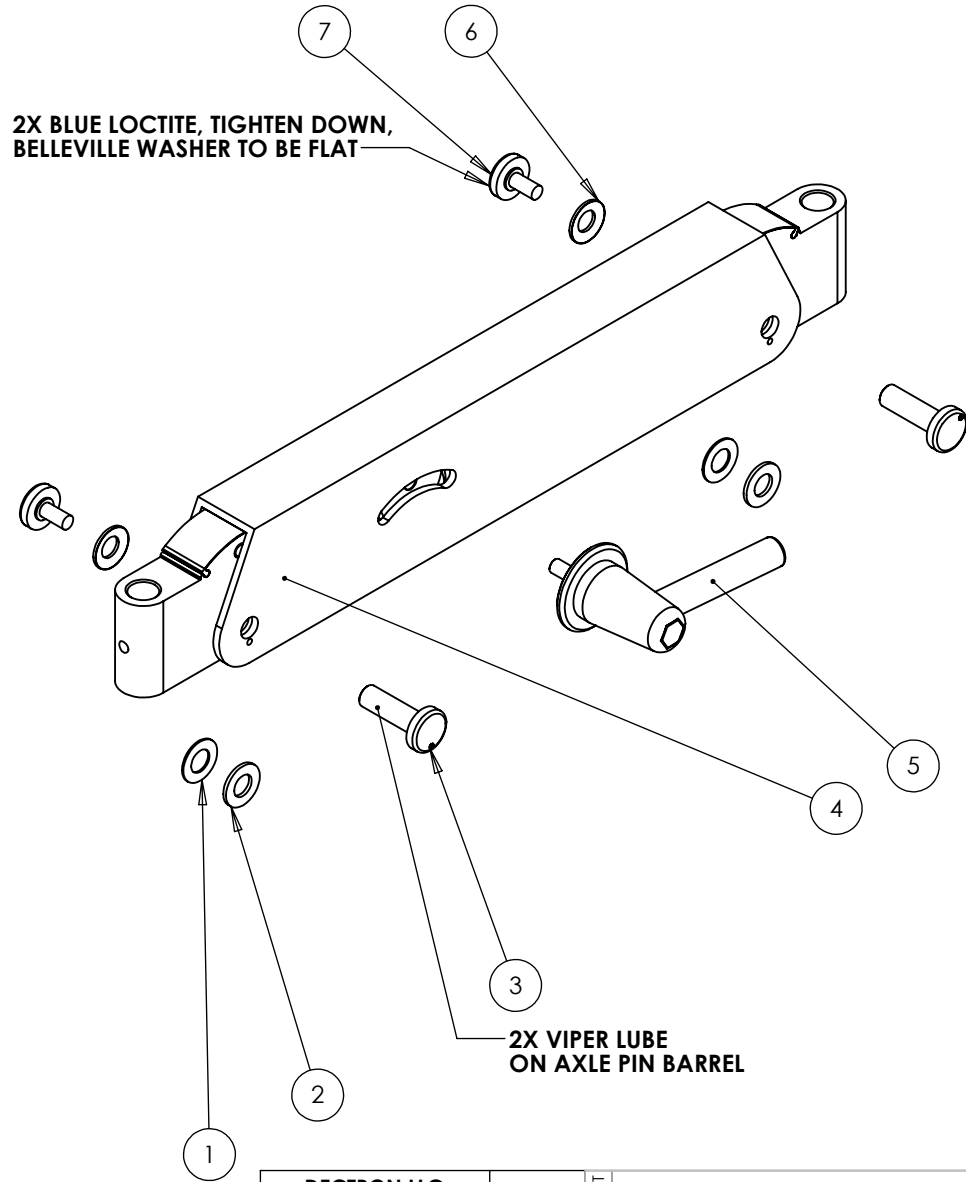

NOTES:
1. VIPER LUBE TO BE USED FOR ALL GREASING

DECTRON LLC www.dectronusa.com		TOLERANCE STANDARDS .x ±.025 .xx ±.010 .xxx ±.005	REV 2
<small>PROPRIETARY & CONFIDENTIAL THE INFORMATION CONTAINED IN THIS DRAWING IS THE SOLE PROPERTY OF DECTRON LLC. ANY REPRODUCTION IN PART OR AS A WHOLE WITHOUT THE WRITTEN PERMISSION OF DECTRON LLC IS PROHIBITED.</small>		40-0070-00	40 SERIES FLEX SECTION, 1/2" THRU HOLE, 3-12 LB CAPACITY, BLACK
SIZE A DRAWN CHASE CHECKED	DO NOT SCALE DRAWING 02.05.20	ANGULAR DECIMAL ±2°	VARIABLES BLACK ANODIZE