

NO	PART#	REV	NAME	QTY.
1	21-0218-00	1	PLATE, STUD MOUNT, BLACK	1
2	21-0077-00	3	BLOCK, MOUNTING, BLACK	1
3	001-010-00		FHSC SCREW 10-32 x 0.75 LG, SS	2
4	016-006-00		BEARING, SLEEVE, BRONZE, .625 OD x .50 ID x .375	1
5	016-011-00		BEARING, SLEEVE, OILITE, .625 OD x .50 ID x 1.0	1
6	007-031-00		SET SCREW, 1/4-28 X 3/16, BLACK OXIDE	1

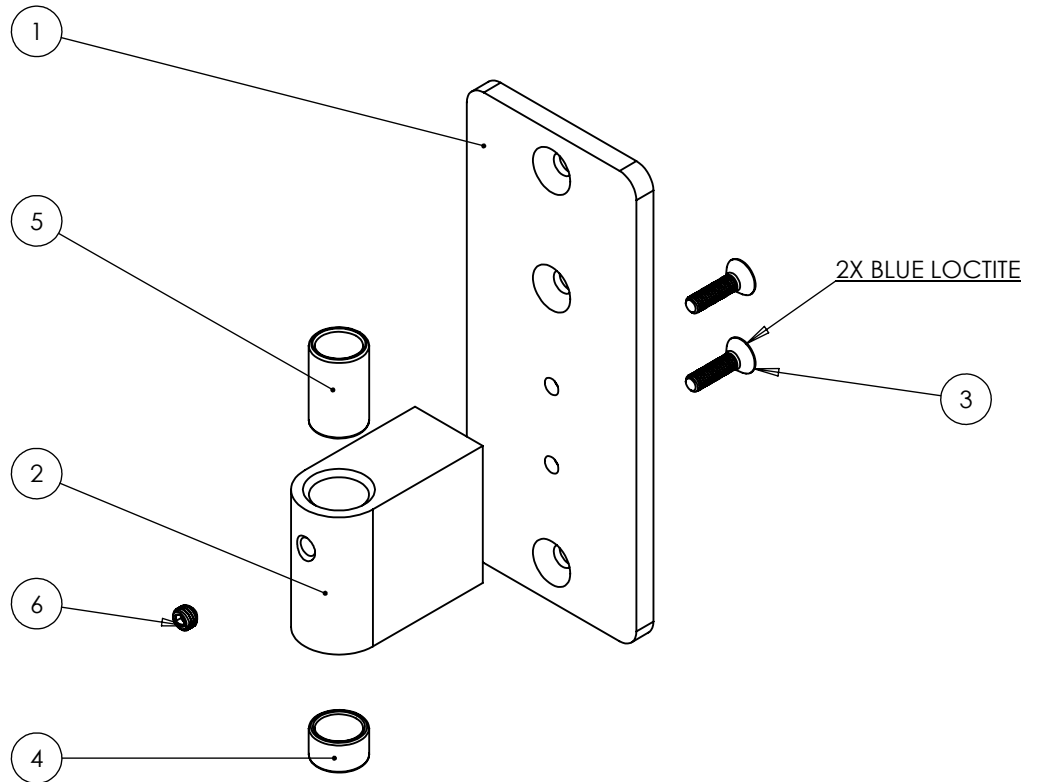
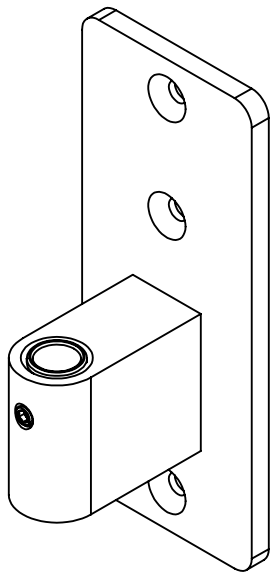
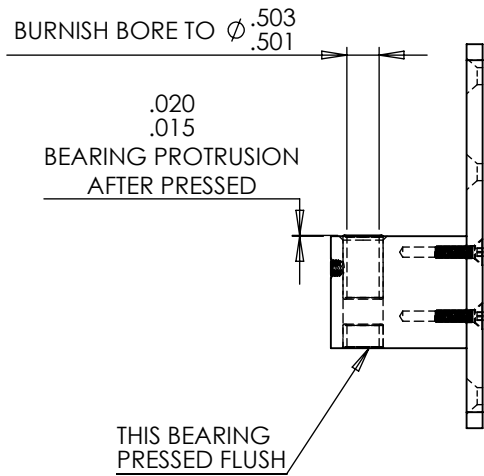

5

4

3

2

1

<b>DECTRON LLC</b> 9750 SW WILSONVILLE ROAD SUITE 300 WILSONVILLE, OR 97070		<b>PART</b> <b>20-0017-00</b>	<b>REV</b> <b>2</b>
<small>PROPRIETARY &amp; CONFIDENTIAL  THE INFORMATION CONTAINED IN THIS  DRAWING IS THE SOLE PROPERTY OF  DECTRON AND STROHMAIER  CORPORATION. ANY REPRODUCTION IN  PART OR AS A WHOLE WITHOUT THE  WRITTEN PERMISSION OF DECTRON OR  STROHMAIER CORPORATION IS PROHIBITED.</small>		<b>TOLERANCES</b> DECIMAL: .X ±.025 .XX ±.010 .XXX ±.005	<b>TITLE</b> <b>FRICITION SERIES STUD MOUNT</b>
<b>SIZE</b> A DO NOT SCALE DRAWING	<b>DRAWN</b> CHASE <b>11/19/19</b>	<b>ANGULAR:</b> ±2°	<b>MATERIAL</b> ALUMINUM
<b>CHECKED</b>			<b>FINISH</b> BLACK